

SKU :

- 1. **Specification:** ASME B18.2.5.M
- 2. **Thread Diameter + Pitch:** M16X2.0
- 3. **Length:** 100mm
- 4. **Thread Amount:** Partial Thread
- 5. **Threaded Length:** 38mm +/- 3mm
- 6. **Unthreaded Length:** 62mm +/- 3mm
- 7. **Material:** Class 12.9 Steel
- 8. **Finish:** Black Oxide
- 9. **Flange Type:** Smooth
- 10. **Flange Width:** 23.95mm
- 11. **Flange Thickness:** 5.93mm
- 12. **Head Height:** 16mm
- 13. **Drive:** 16mm 12-Point Wrench
- 14. **Type Screw/Bolt:** 12-pt Flange
- 15. **Thread Direction:** Right Hand
- 16. **Measurement System:** Metric

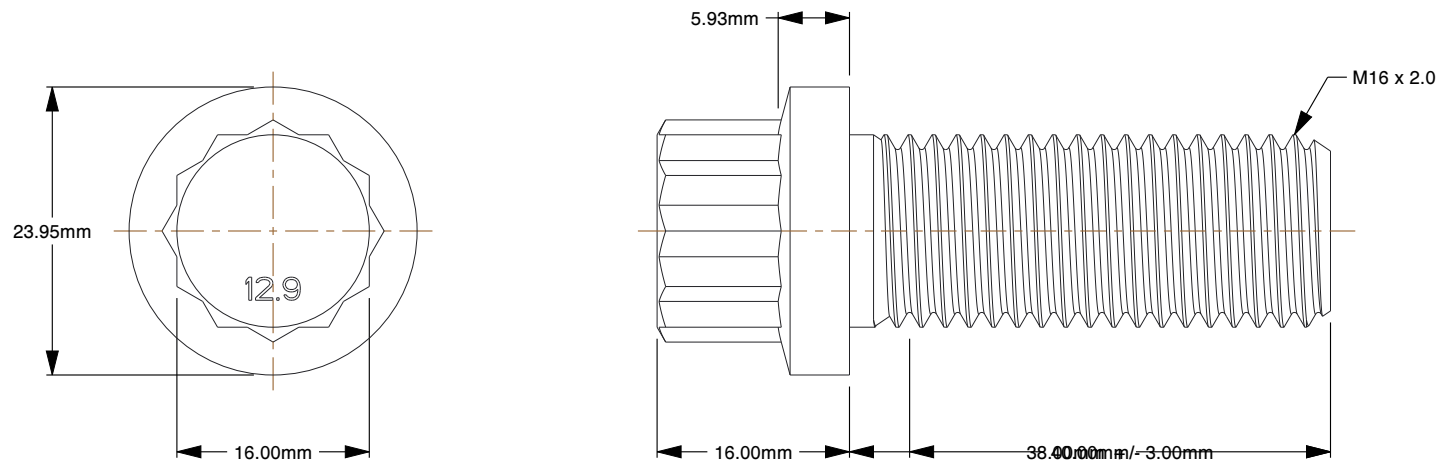
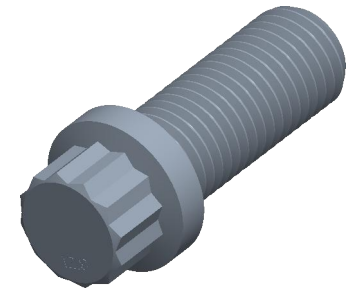

	<p>This file and any associated information and specifications are provided for reference and evaluation purposes only and is subject to change without notice. _____ makes no representations, warranties, or guarantees as to the appropriateness, accuracy, completeness, or suitability for any purpose of the file, information or specifications. You are solely responsible for the use of the file, information, or specifications.</p>	<p>This document is the property of _____ and the information it contains may not be reproduced, disclosed, or shared with any third party without the expressed written permission of _____.</p>	<p>PRODUCT NAME M16 12-Point Flange Bolt Steel Class 12.9 Black ASME B18.2.5.M</p>	<p>UNIT 2dpdf</p>
			<p>PART NUMBER:</p>	<p>ISSUED 2dpdf</p>
		<p>SCALE 1.591</p>		<p>SHEET 1 of 1</p>